

CHARGESPOT SPECIFICATION GUIDE



CONTENTS

3	Price List
4	Installation
6	Sample Layout Specifications
10	Documents
13	Specifying ChargeSpot



End User Price List

LAST UPDATED: JULY 12, 2017



Model	L	W	H	Price
TX01002				\$ 180
ChargeSpot	3 1/2"	3 1/2"	3/4"	
Mounting Plate	4 1/2"	4 1/2"	3/4"	
Black Decal	2"	2"		
White Decal	2"	2"		



Model	L	W	H	Price
RX01002				\$ 30
Apple Lightning Spark	2 1/2"	1 9/10"	1/2"	



Model	L	W	H	Price
RX01003				\$ 30
microUSB Spark	2 1/2"	1 9/10"	1/2"	



Model	L	W	H	Price
RX01004				\$ 30
USB-C Spark	2 1/2"	1 9/10"	1/2"	



Model	L	W	H	Price
WP01009				\$ 15
Spark Holder	4.9"	4.9"	7/8"	

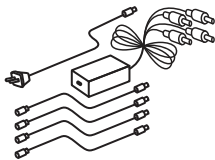

Model	L	W	H	Price
PS01003				\$ 80
AC Cable	4'			
Transformer	5'			
4 DC Cables	6'			
Total Length of Multi Unit Power Supply	15'			

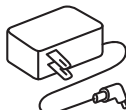

Model	L	W	H	Price
PS01001				\$ 20
Single Unit Power Supply	5'			



INSTALLATION

INSTALLATION OVERVIEW

- The standard layout is one ChargeSpot in between each seat or chair
- (4) ChargeSpots can be powered from (1) socket. (Up to 8 on one standard duplex outlet.)
- All ChargeSpot Dealers have trained installation staff

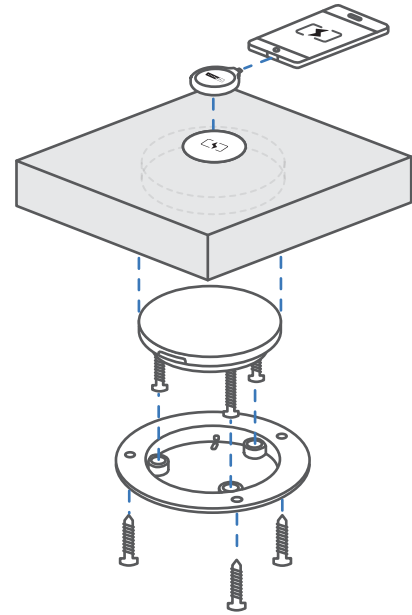

INSTALLED CHARGESPOT

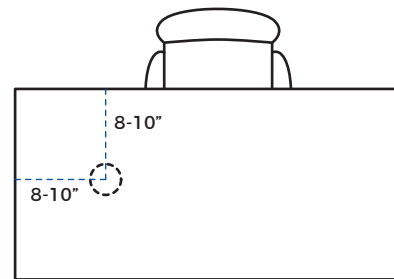
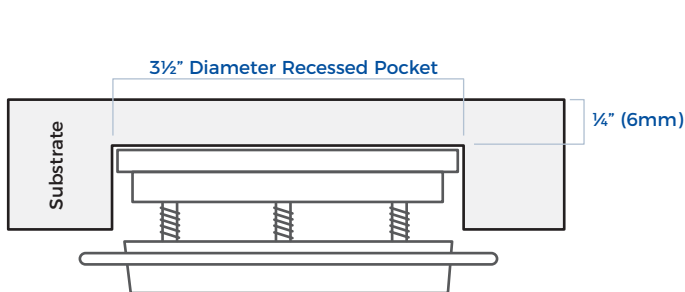

CHARGESPOT W/ MOUNTING PLATE

Routing/milling a "pocket" into the underside of furniture is required to correctly install a chargespot

SUB-SURFACE: TYPES

- | | |
|--------------------------------|---------|
| ✓ Corian | ✗ Metal |
| ✓ Wood | ✗ Glass |
| ✓ Particle Board (MDF) | |
| ✓ Laminate | |
| ✓ Granite and other hard stone | |



INSTALLATION

PLACEMENT: HOW IT FITS ON THE TABLE

- 8-10 inches from the edge of table
- Spaced equidistant between two seats
- Max 8 units/ electrical outlet

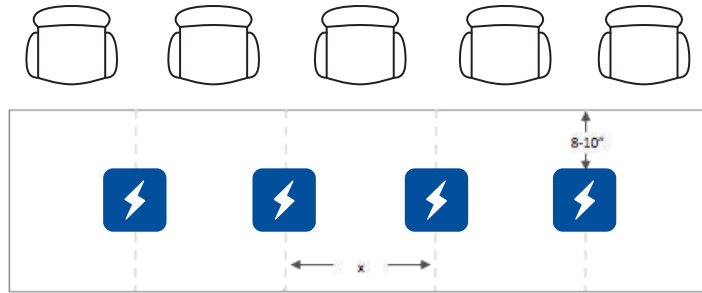

POWER REQUIREMENTS

Single Unit Configuration powers one ChargeSpot

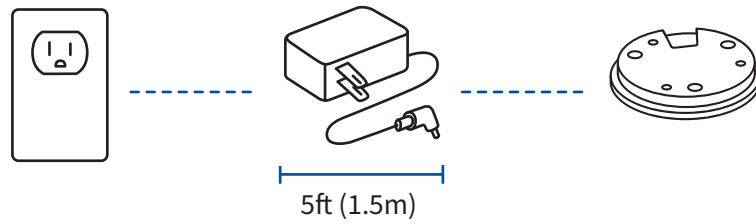

Multi-Unit Configuration powers up to 4 ChargeSpots

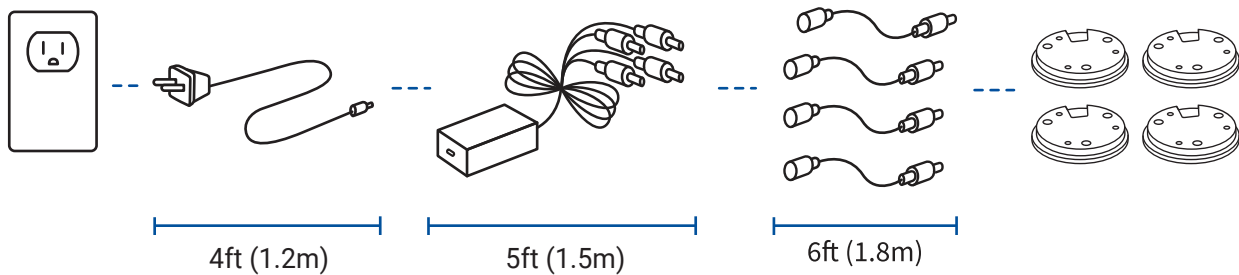

10 SEAT, 8 CHARGESPOTS - RECTANGULAR TABLE

 ChargeSpot

 Spark holder

x = equal distances

*not to scale

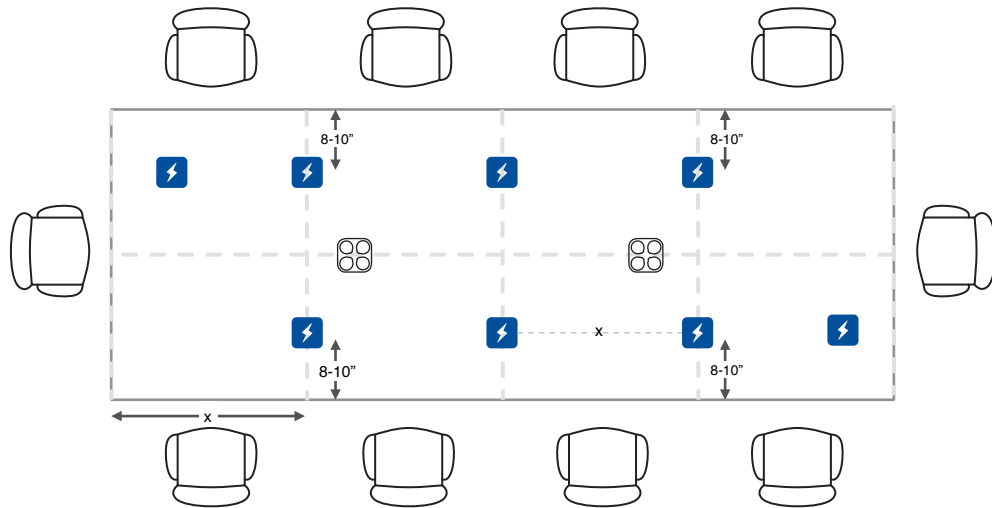

© ChargeSpot Wireless Power Inc



SKU'S REQUIRED

#REQUIRED	SKU	DESCRIPTION
8	TX01002	ChargeSpot
2	PS01006	Multi Unit Power Supply
8	RX01002	Spark (Apple)
4	WP01009	Spark Holder

Want to see more? View our full sample layout library



6 SEATS, 4 CHARGESPOTS - CIRCULAR TABLE

-  ChargeSpot
-  Spark holder

x = equal distances
not to scale

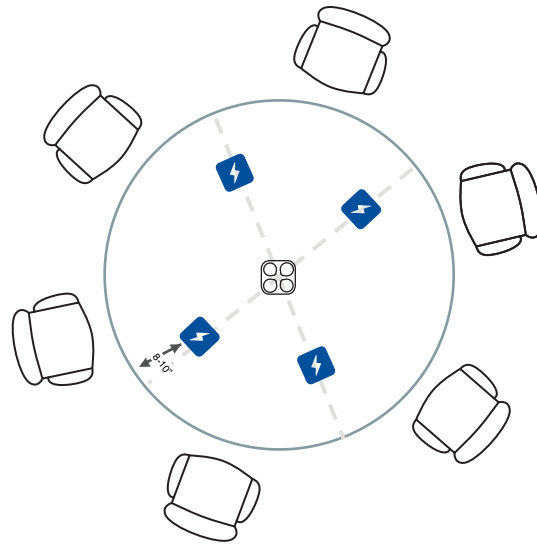

© ChargeSpot Wireless Power Inc

SKU'S REQUIRED

#REQUIRED	SKU	DESCRIPTION
4	TX01002	ChargeSpot
1	PS01006	Multi Unit Power Supply
4	RX01003	Spark (mUSB)
1	WP01009	Spark Holder

Want to see more? View our full sample layout library



10 SEATS, 10 CHARGESPOTS - INDIVIDUAL WORK STATIONS - BENCHING

 ChargeSpot

x = equal distances

*not to scale

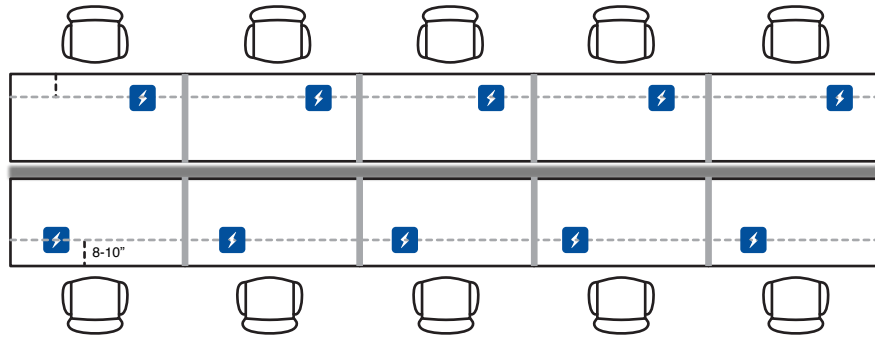

© ChargeSpot Wireless Power Inc

SKU'S REQUIRED

#REQUIRED	SKU	DESCRIPTION
10	TX01002	ChargeSpot
10	PS01005	Single Unit Power Supply
4	RX01003	Spark (mUSB)
4	RX01002	Spark (Apple)
2	RX01004	Spark (USB-C)

Want to see more? View our full sample layout library



1 SEAT, 1 CHARGESPOT - INDIVIDUAL WORK STATION



x = equal distances

*not to scale

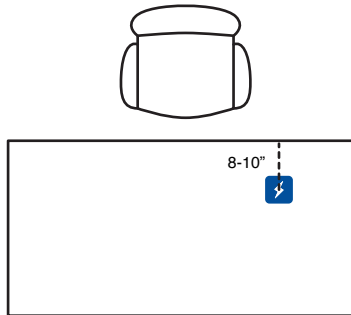

© ChargeSpot Wireless Power Inc

SKU'S REQUIRED

#REQUIRED	SKU	DESCRIPTION
1	TX01002	ChargeSpot
1	PS01005	Single Unit Power Supply

Want to see more? View our full sample layout library



FCC & INDUSTRY CANADA COMPLIANCE

The OEM shall inform end users of the following to the extent applicable:

This device complies with Part 15 of the FCC Rules and with Industry Canada license-exempt RSS Standard(s). Operation is subject to the following two conditions: (1) this device may not cause harmful interference, and (2) this device must accept any interference received, including interference that may cause undesired operation.

“Le présent appareil est conforme aux CNR d’Industrie Canada applicables aux appareils radio exempts de licence. L’exploitation est autorisée aux deux conditions suivantes: (1) l’appareil ne doit pas produire de brouillage, et (2) l’utilisateur de l’appareil doit accepter tout brouillage radioélectrique subi, même si le brouillage est susceptible d’en compromettre le fonctionnement.”

Changes or modifications not expressly approved by CHARGESPOT could void the user’s authority to operate the equipment.

This equipment has been tested and found to comply with the limits for a Class B digital device, pursuant to Part 15 of the FCC Rules. These limits are designed to provide reasonable protection against harmful interference in a residential installation. This equipment generates, uses, and can radiate radio frequency energy, and, if not installed and used in accordance with the instructions, may cause harmful interference to radio communications. However, there is no guarantee that interference will not occur in a particular installation. If this equipment does cause harmful interference to radio or television reception, which can be determined by turning the equipment off and on, the user is encouraged to try to correct the interference by one or more of the following measures:

- Reorient or relocate the receiving antenna
- Increase the separation between the equipment and receiver
- Connect the equipment into an outlet on a circuit different from that to which the receiver is connected
- Consult the dealer or an experienced radio/TV technician for help

This Class B digital apparatus complies with Canadian ICES-003.

Cet appareil numérique de la classe B est conforme à la norme NMB-003 du Canada



TERMS & CONDITIONS

ChargeSpot Wireless Power Inc. (“**ChargeSpot**”) provides products, which enable wireless charging of mobile devices that can be installed at an office or venue. All products purchased from or provided by ChargeSpot, or its authorized representative, pursuant to an invoice or Sales Order, which references and incorporates these terms will be subject to the following Terms and Conditions of Sale (the “**Terms**”).

1. **Definitions:** the following defined terms have the following meanings in these Terms:

“**Customer**” means the company or other legal entity purchasing ChargeSpot products from ChargeSpot or its authorized representative on the terms of this Agreement;

“**Sales Quotation**” means a non-binding document setting out anticipated pricing for ChargeSpot products which remains open for the period of time indicated in the quotation; and

“**Sales Order**” means a document that is signed by the customer and which sets out pricing for ChargeSpot products together with the volumes of products, special use restrictions and any other information agreed between the parties relating to an order.

ORDER TERMS

2. **Orders:** All Sales Orders accepted by ChargeSpot shall be governed by these Terms and by any additional terms and conditions, which are expressly agreed upon by authorized representatives of the parties in writing. ChargeSpot shall have no obligation to accept any purchase order or order request.
3. **Modifications to Orders; Changes:** All requests for order modifications to Sales Orders must be submitted in writing to ChargeSpot and will not bind ChargeSpot unless agreed to in writing by an authorized ChargeSpot signing officer. ChargeSpot reserves the right to introduce improvements, enhancements, modifications or substitutions for any services, products or product components supplied, notwithstanding any specific provision of these Terms or a Purchase Order, provided that such modification or substitution maintains or does not introduce a material degradation in the overall performance of the product.

4. **Payment and Currency:** Customer shall pay to ChargeSpot the fees set out in the applicable Purchase Order. Unless otherwise specified in a Purchase Order or invoice issued by ChargeSpot, payment shall be due within thirty (30) days from the date of the ChargeSpot invoice. All product prices and amounts payable shall be payable in the currency indicated on the Purchase Order. If any payment, or any other sum due to ChargeSpot under these Terms, becomes past due for more than thirty (30) days, ChargeSpot may, without declaring Customer to be in default, charge Customer a late payment charge of one point five percent (1.5%) per month or the maximum rate legally permitted, whichever is less. All fees exclude all taxes, which the Customer shall pay to ChargeSpot.

WARRANTY PROVISIONS

5. **Product Warranty.** ChargeSpot's sole warranty obligation for any product that is or becomes defective in material or workmanship within twelve (12) months from the date of shipment shall be limited to the replacement or repair of the defective goods or services free of charge. ChargeSpot's warranty obligations hereunder are contingent upon the following conditions: ChargeSpot is promptly notified of the defect; Customer establishes to ChargeSpot's reasonable satisfaction that any goods have been properly operated; the goods were not materially altered; and upon ChargeSpot's request, Customer will return the defective goods or part thereof to ChargeSpot.
6. **Warranty Claims Procedure:** All claims must be made in writing during the warranty period and within thirty (30) days of the date the warranty breach is discovered or should have reasonably been discovered. Claims outside of the warranty period will be invalid. The Customer is required to arrange for all product shipments to ChargeSpot

TERMS & CONDITIONS

for warranty repair and is responsible for all shipping and handling costs to ChargeSpot's facilities. ChargeSpot will pay reasonable return shipping and handling charges, provided the warranty claim is found by ChargeSpot to be valid.

7. **Warranty Repair or Replacement:** ChargeSpot will either repair or replace, at ChargeSpot's sole option, any product, which fails during the warranty period due to a defect in workmanship and/or materials, or to refund the purchase price (upon return of the product, if requested by ChargeSpot), the choice of which is at ChargeSpot's sole option. All replaced products (or components thereof) shall become ChargeSpot's property.
8. **Warranty Limitations:** The foregoing are the Customer's sole and exclusive remedies and ChargeSpot's sole and exclusive obligations and liabilities for breach of the warranty by ChargeSpot. All warranties shall immediately become null and void should ChargeSpot, in its sole discretion, determine that the products have been subject to unauthorized modification, misuse, abuse, neglect, accident, or handling or if the serial number and/or other identifying markings have been defaced, removed or altered.

LIABILITY PROVISIONS

9. **DISCLAIMER.** EXCEPT FOR THE EXPRESS WARRANTY UNDER THE SECTION ABOVE ENTITLED "WARRANTY PROVISIONS", THE PRODUCTS ARE SUPPLIED ON AN "AS IS" BASIS AND THERE ARE NO WARRANTIES, REPRESENTATIONS OR CONDITIONS, EXPRESS OR IMPLIED, WRITTEN OR ORAL, ARISING BY STATUTE, OPERATION OF LAW, COURSE OF DEALING, USAGE OF TRADE OR OTHERWISE, REGARDING THEM OR ANY OTHER PRODUCT OR SERVICE PROVIDED HEREUNDER OR IN CONNECTION HERewith BY CHARGESPOT OR ITS AUTHORIZED REPRESENTATIVES. CHARGESPOT DISCLAIMS ANY IMPLIED WARRANTIES OR CONDITIONS OF MERCHANTABILITY, SATISFACTORY QUALITY, MERCHANTABILITY, DURABILITY OR FITNESS FOR A PARTICULAR PURPOSE. IN PARTICULAR, AND CHARGESPOT DISCLAIMS ANY IMPLIED

WARRANTIES OR CONDITIONS OF MERCHANTABILITY, SATISFACTORY QUALITY, MERCHANTABILITY, DURABILITY OR FITNESS FOR A PARTICULAR PURPOSE. IN PARTICULAR, AND WITHOUT LIMITING THE FOREGOING, THE PRODUCTS ARE NOT FAULT TOLERANT AND ARE NOT DESIGNED FOR USE IN ENVIRONMENTS REQUIRING FAIL SAFE PERFORMANCE.

- Customer Indemnity.** To the maximum extent allowed by law, Customer shall reimburse, indemnify and hold ChargeSpot and its employees and agents harmless from and against any claims, demands, liabilities, damages, suits, judgments, losses, costs and/or expenses (including attorneys' fees and other expenses of any litigation) suffered and paid by ChargeSpot (collectively, "Losses") that relates to or arises on account of (a) Customer's negligence, use, ownership, maintenance, transfer, transportation or disposal of the products; or (b) Customer's violation or alleged violation of any federal, state, county or local law, rule or regulation.

GENERAL PROVISIONS

- Contingencies.** Dates and times by which
11. ChargeSpot is required to render performance under these Terms shall be automatically postponed to the extent and for the period that ChargeSpot is prevented from meeting them by reason of any cause beyond its reasonable control. ChargeSpot shall notify Customer of the commencement and nature of such cause and uses its reasonable efforts to render performance in a timely manner.

- Disputes and Governing Law.** These Terms shall
12. be governed by and construed in accordance with the laws of the Province of Ontario and the laws of Canada applicable therein without regard to its conflict of laws provisions. Customer and ChargeSpot submit to the non-exclusive jurisdiction of the courts of the Province of Ontario. Any action resulting from any breach on the part of ChargeSpot as to the goods or services delivered hereunder must be commenced within one year after the cause of action has accrued.

CHARGESPOT

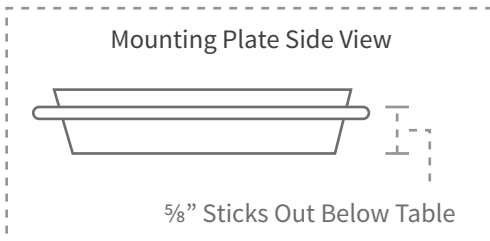
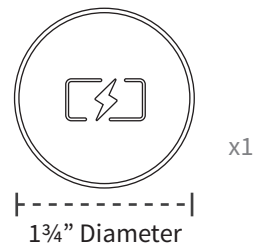
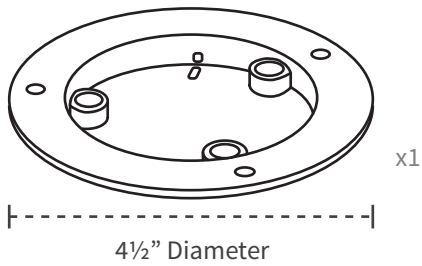
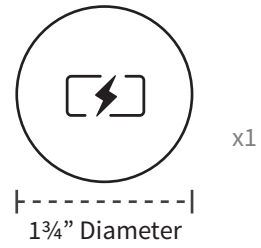
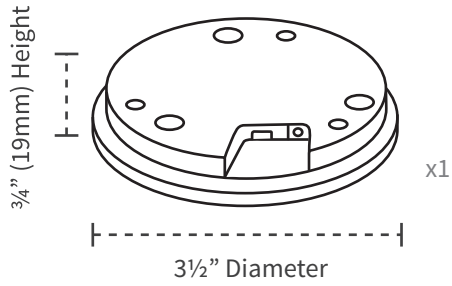

SKU	STANDARD INCLUDES
TX01001A	1 ChargeSpot
	1 Mounting Plate
	1 Black Decal
	1 White Decal



SPARK (APPLE LIGHTNING)

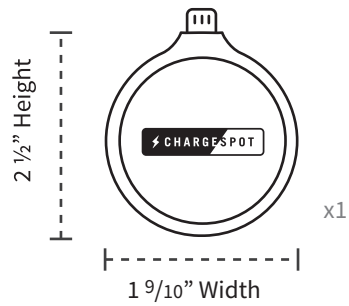

SKU

STANDARD INCLUDES

RX01002

1 Apple Lightning Spark

SPARK (MICRO USB)

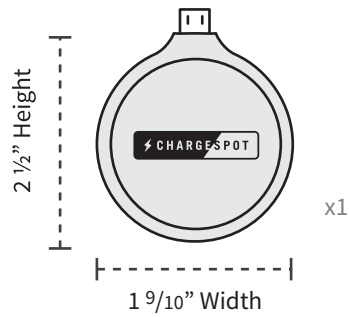

SKU

STANDARD INCLUDES

RX01003

1 MicroUSB Spark

SPARK (USB-C)

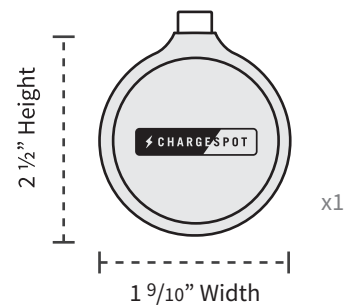

SKU

STANDARD INCLUDES

RX01004

1 USB-C Spark



SPARK HOLDER

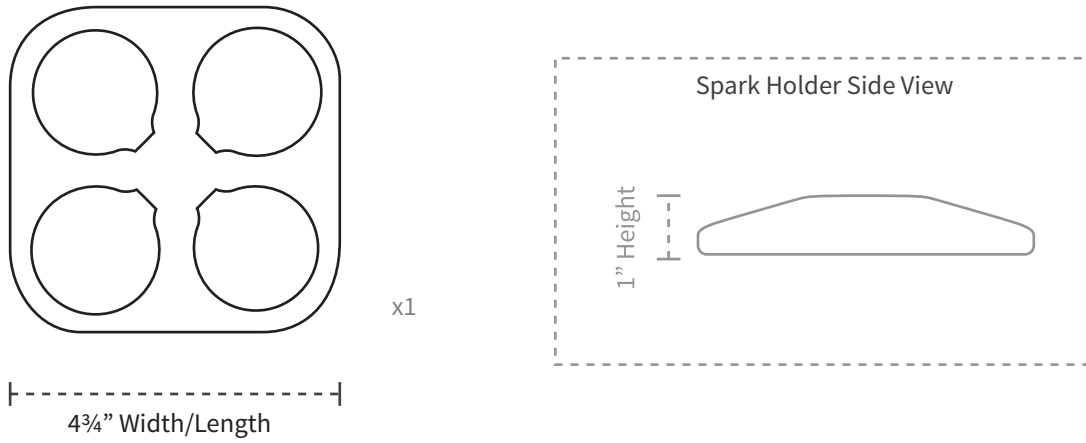

SKU	STANDARD INCLUDES
-----	-------------------

WP01009	1 Spark Holder
---------	----------------

MULTI-UNIT POWER SUPPLY

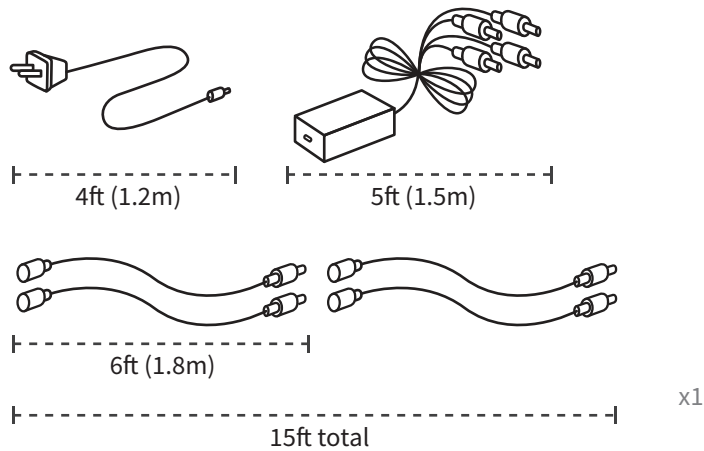

SKU	STANDARD INCLUDES
-----	-------------------

PS01003	1 19V Multi-Unit Power Adapter with 12 ft Length 4-Unit Power Supply
---------	--

Note for transformer only
 Length = 5 3/8" (136mm)
 Width = 2 1/4" (59mm)
 Height = 1 3/8" (35mm)



SINGLE-UNIT POWER SUPPLY

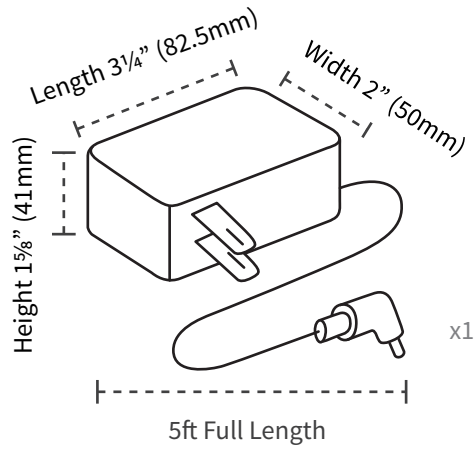

SKU

STANDARD INCLUDES

PS01001

1 19V Power Adapter Single Unit Power Supply

